

BE1280T0B0A

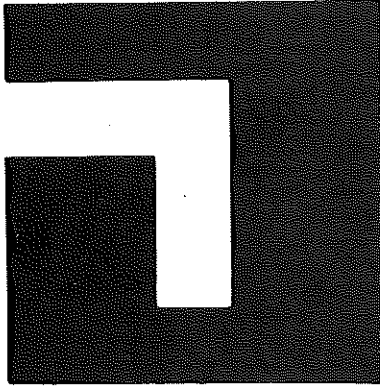

MODEL **LZ-1280** Series

1-NEEDLE ZIGZAG LOCKSTITCH  
SEWING MACHINE

---

---

# INSTRUCTION BOOK

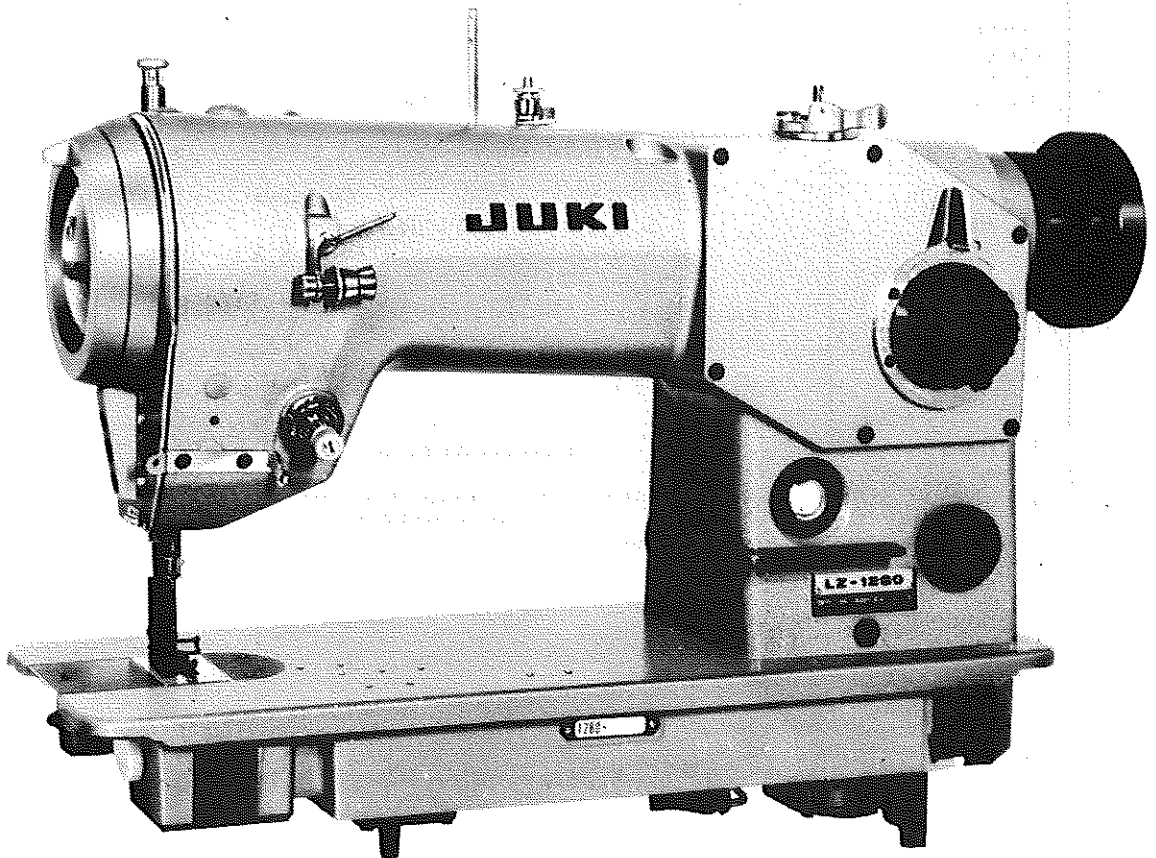

**TOKYO JUKI INDUSTRIAL CO., LTD.**

## INTRODUCTION

This is the INSTRUCTION BOOK for the operators of JUKI 1-Needle, Zigzag Lockstitch Sewing Machine, Model LZ-1280 series. Please carefully read this book and efficiently use your sewing machine.

## SPECIFICATIONS

	LZ-1280	LZ-1286	LZ-1287
Type of zigzag	Standard zigzag	3-step zigzag	Scallop
Sewing speed (Maximum)	5500 s.p.m.	5000 s.p.m.	
Thread take-up	Rotary type thread take-up		
Sewing hook	Special rotary sewing hook, DP type		
Needle	ORGAN SG x 1906 #9 ~ #14 Schmetz 19:18 (SY1906) #70 ~ #90 SINGER 1906 #9 ~ #14		
Zigzag width (Maximum)	5 mm (13/64")	10 mm (25/64")	8 mm (5/16")
Feed pitch (Maximum)	2.5 mm (3/32")	2 mm (5/46")	
Lubrication	Fully automatic lubrication		
Lubricating oil	JUKI New Defrix Oil No. 1 or mixture of 70% of SPINESSO 28 and 30% of SPINESSO 34		

# CONTENTS

<b>I. INSTALLATION AND PREPARATION</b> .....	1
1. Setting up the machine .....	1
2. Motor pulley and belt .....	1
3. Installing the belt cover .....	2
4. Needle positioner (option) .....	2
5. Lubrication .....	2
<b>II. OPERATION</b> .....	3
1. Cautions .....	3
2. Inserting a needle .....	3
3. Winding up the bobbin .....	4
4. Inserting and removing the bobbin case .....	4
5. Placing a bobbin into the bobbin case .....	4
6. Threading the machine .....	5
7. Adjusting the thread tensions .....	5
8. Adjusting the pressure of the presser foot .....	6
9. Adjusting the zigzag width .....	7
10. Needle position adjusting lever .....	7
11. Adjusting the stitch lengths for the forward and reverse feed .....	8
<b>III. ADJUSTMENT</b> .....	9
1. Height of the feed dog .....	9
2. Removing and inserting the sewing hook .....	9
3. Relationship between the needle and the sewing hook .....	10
4. Adjusting the amount of lubricating oil fed to the sewing hook .....	10
<b>IV. TROUBLES AND CORRECTIVE MEASURES</b> .....	11

# I. INSTALLATION AND PREPARATION

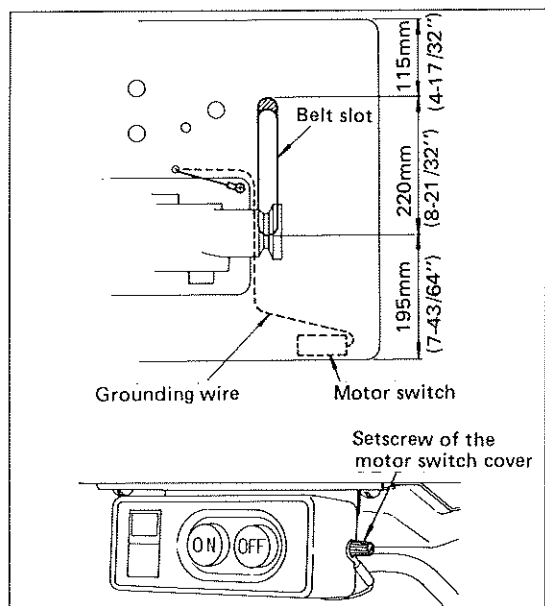

## 1. Setting up the machine

- (1) Install the oil reservoir in the machine table.
- (2) Attach each knee lifter component to the oil reservoir.
- (3) Insert the hinge in the machine head and gently place the machine head on the table.
- (4) Set up the thread stand assembly on the table using wood screws and hammer the head support into the table.
- (5) Connect one end of a grounding wire to a setscrew of the motor switch cover and another end to the screw in the rear right of the machine as illustrated. Fasten the grounding wire in the middle using staples supplied with the machine.

**(Caution)** If the machine head is mounted on a table designed for ordinary lockstitch machines, cut the belt slot in the size detailed below.

## 2. Motor pulley and belt

- (1) The driving motor of this machine is a 400 watts (2P) clutch motor.
- (2) Use a M type V-belt.
- (3) The attainable sewing speeds are determined by the diameter of the motor pulley and the length of the belt as listed below.

Effective diameter of the motor pulley (mm)	Motor pulley Part No.	Sewing speed (s.p.m)		Belt length (inch)	Belt Part No.
		50 Hz	60 Hz		
130	MTKP0130000	5480		46	MTJVM004600
125	MTKP0125000	5270			
120	MTKP0120000	5060		45	MTJVM004500
115	MTKP0115000	4850			
110	MTKP0110000	4630		44	MTJVM004400
105	MTKP0105000	4440	5330		
100	MTKP0100000	4250	5040		
95	MTKP0095000	4000	4780		
90	MTKP0090000	3820	4540	43	MTJVM004300
85	MTKP0085000	3610	4320		
80	MTKP0080000	3390	4000		
75	MTKP0075000	3160	3790		
70	MTKP0070000	2950	3520		
65	MTKP0065000	2740	3260		

(Note) The effective diameter of the motor pulley is obtained by subtracting 5 mm (13/64") from the outer diameter of the pulley.

**(Caution)** The rotational direction of the machine is counter-clockwise as viewed from the pulley side. Take care not to run it reversely.

### 3. Installing the belt cover

Install the belt cover as illustrated.

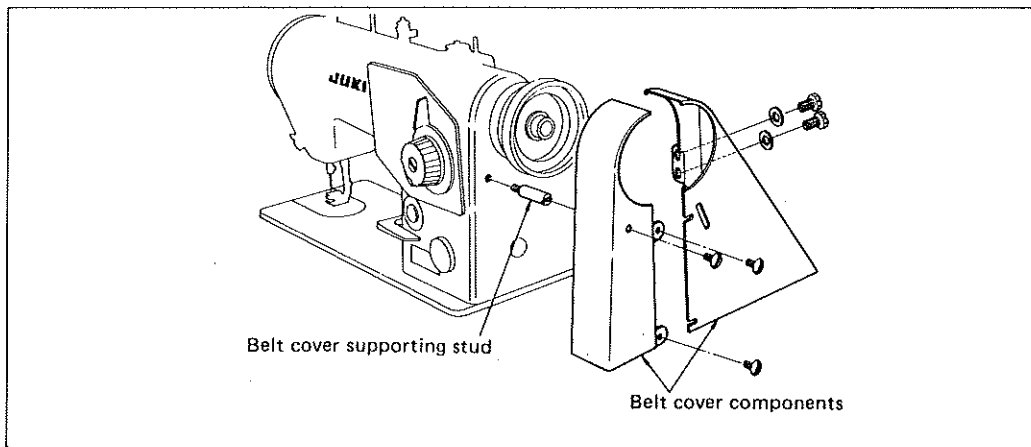

### 4. Needle positioner (option)

When the needle positioner is installed in your machine, the machine stops always with the needle in raised position, promoting efficiency in the sewing work. Fix the synchronizer bracket (optional attachment) to the belt cover in the position as illustrated using suitable bolts and nuts and fasten the synchronizer to the bracket.

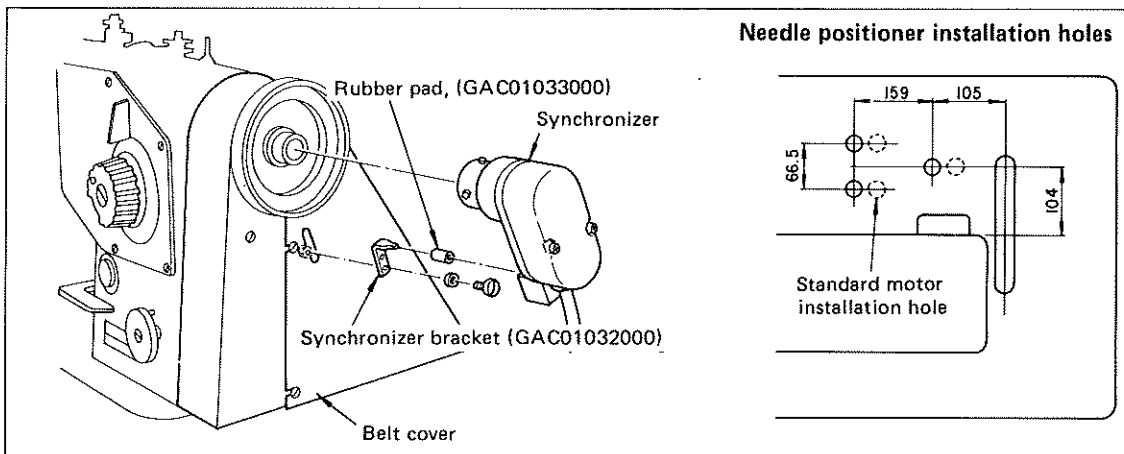

(Note) When the needle positioner is installed in your machine, the installation holes must be changed to the locations as shown in the above drawing.

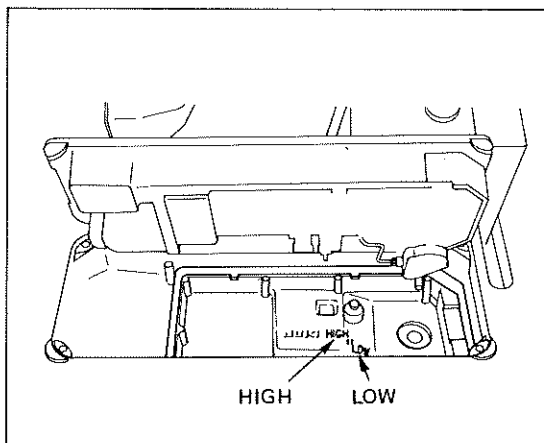

### 5. Lubrication

- (1) Before operation, fill the oil reservoir with JUKI New Defrix Oil No. 1 up to the level of "HIGH" mark.
- (2) Regularly check the oil level and add the oil when necessary. Do not operate the machine when the oil level is below "LOW" mark.

## II. OPERATION

### 1. Cautions



- (1) Never operate the machine before filling up the oil reservoir with the lubricating oil.
- (2) Always use the clean oil. Remove the oil drain cap from the bottom of the oil reservoir, and the reservoir will be drained.
- (3) Provide an initial machine warm-up period of about ten minutes at a speed of 3000 to 3500 s.p.m. before operating a machine which is newly set up or has not been used for a long period of time.
- (4) Operate the machine at a sewing speed lower than 4000 s.p.m. for the first one month.
- (5) Do not forget to cut off the power supply when you tilt the machine head back for cleaning or lubrication or when you remove the belt.

### 2. Inserting a needle

Select a suitable needle among the listed needles having different shapes of the tip and sizes for the thickness of the thread and the type of sewing material.

The ball-point needle may be effective to prevent the texture of fabric from breaking.

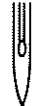
#### Usable needles

ORGAN	SCHMETZ	SINGER	Shape of needle point		Needle No.
SG x 1906	19:18 (SY 1906)	1906		ORGAN Schmetz SINGER	9, 10, 11, 70, 75, 80, 90 9, 10, 11, 12, 14
————	19:18EB (SY 1963)	1963		Schmetz SINGER	70, 75, 80, 90 10, 11, 12, 14
SG x 1906	19:18BF (SY 1965)	1965		ORGAN Schmetz SINGER	9U, 10U, 11U, 70, 75, 80, 90 10, 11, 12, 14

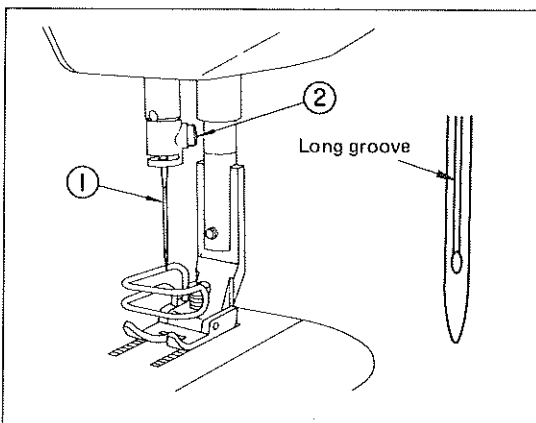

#### Inserting a needle :

- (1) Make sure first that the main switch is "off" and the motor stops.
- (2) Turn the handwheel by hand to raise the needle bar to the highest point.
- (3) Hold needle ① facing its long groove toward you and insert into the needle bar as far as it will go.
- (4) Securely tighten screw ② .

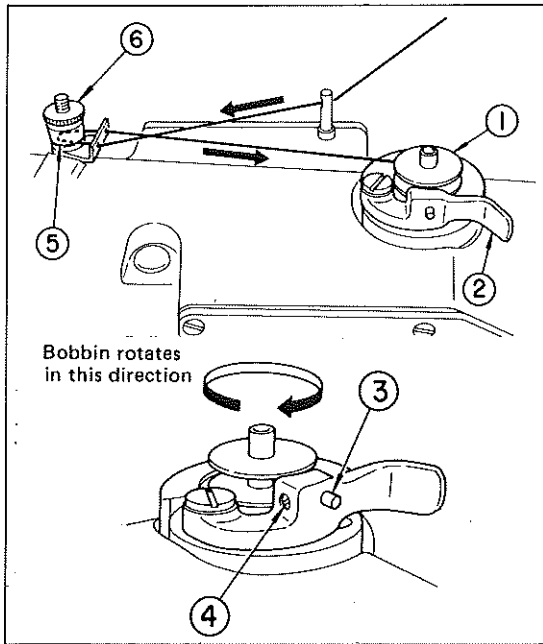

### 3. Winding up the bobbin

- (1) Thread the bobbin winder components as illustrated and wind the end of the thread on the bobbin ① several turns.
  - (2) Press lever ② against the bobbin winder, and the bobbin will be wound up as the motor runs.
  - (3) As soon as the bobbin is filled up, the winding automatically stops.
  - (4) Adjust the bobbin winder so that it stops winding when about 80% of a bobbin is filled up; loosen setscrew ④ and adjust it with pin ③.
  - (5) If the bobbin is not wound up evenly, adjust the height of spindle ⑤.
- (Caution)** Take care not to tightly wind the bobbin when synthetic thread is used. The thread tension applied to the winder can be adjusted by tension nut ⑥.

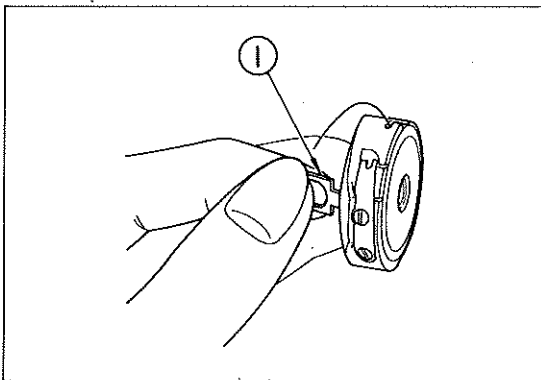

### 4. Inserting and removing the bobbin case

- (1) Turn the handwheel by hand to raise the needle to the highest point.
  - (2) Raise the bobbin case latch ① and hold it between your two fingers.
  - (3) Insert the bobbin case as it is being held into the sewing hook as far as it will go.
  - (4) Release the bobbin case latch to let it steadily rest in the closing position.
- (Note)** Reverse the above procedures when removing the bobbin case.

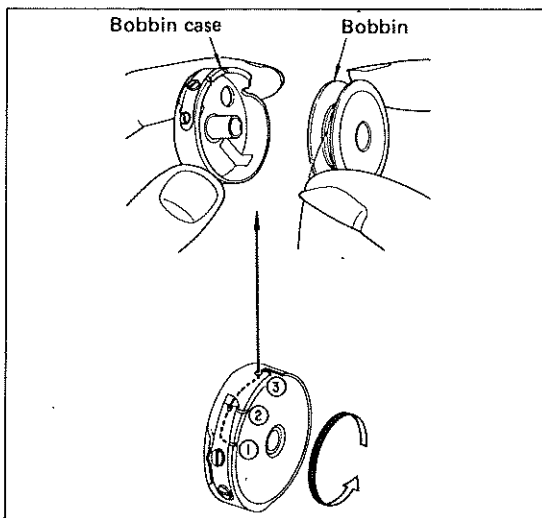

### 5. Placing a bobbin into the bobbin case

- (1) Take bobbin by your right hand with the thread drawn out about 2 inches and place it into bobbin case as illustrated.
- (2) Thread the bobbin case in the order of ①, ② and ③ and pull it out through the thread path.
- (3) Make sure that the bobbin rotates in the direction shown by arrow.

## 6. Threading the machine

- (1) Turn by hand the handwheel until the needle reaches its highest point.
- (2) Thread the machine in the illustrated order.
- (3) Wind the thread one and a half turn around the tension controller assembly.
- (4) Pass the thread through the needle eye and pull it out about 4 inches from the eye.

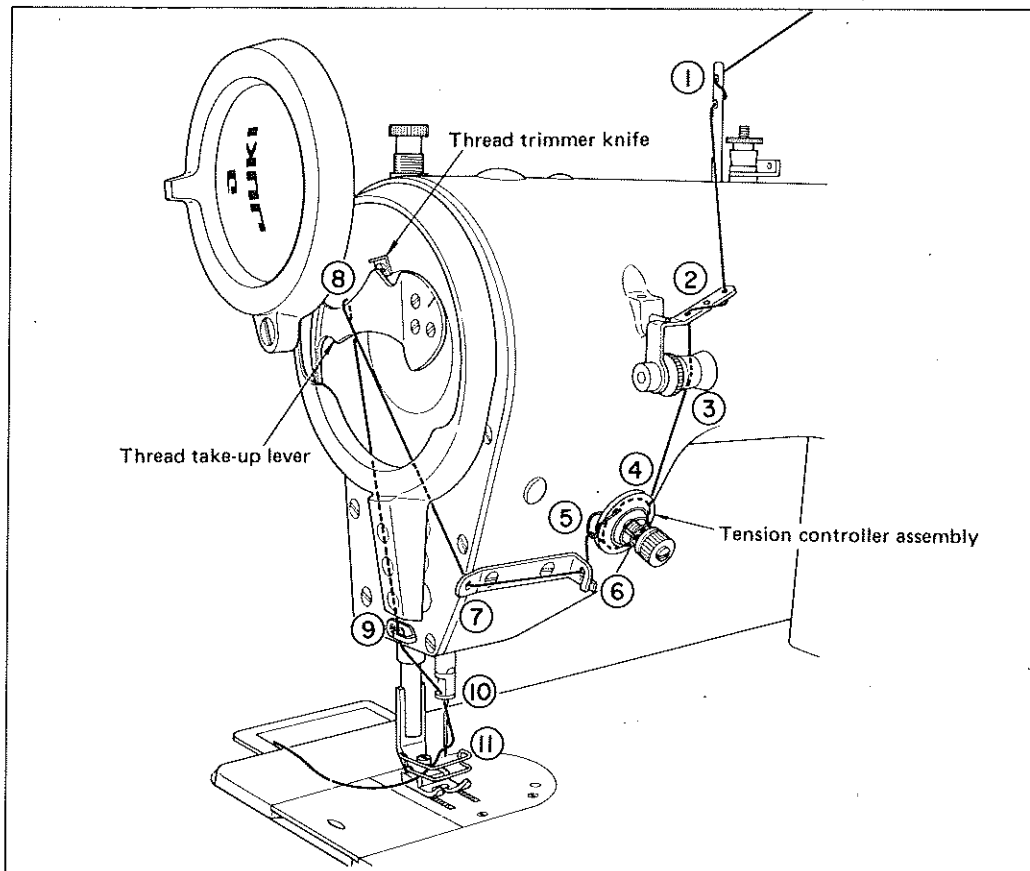

(Note) When the needle thread is broken and gets entangled in the thread take-up components, open the face plate of the thread take-up components and remove the entanglement. There is a thread trimmer knife near the thread take-up lever. Take care not to injure your fingers.

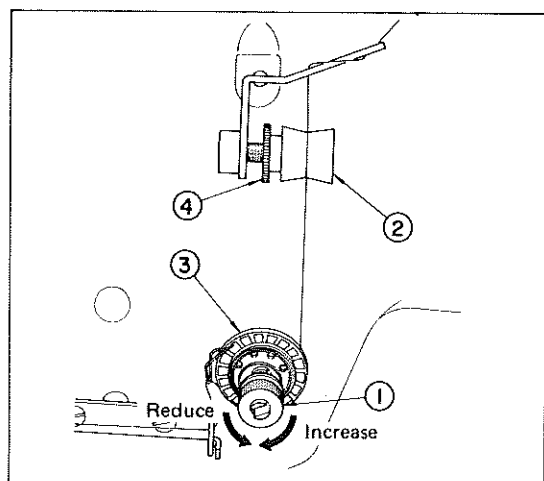

## 7. Adjusting the thread tensions

### Needle thread tension

The needle thread tension is adjusted by tension nut ①; turn it clockwise to increase or counter-clockwise to reduce the tension.

(Caution) If pre-tension disc ② is too loose in comparison with the tension given by tension controller assembly ③ the thread may slip in the tension discs. Adjust pre-tension nut ④ to balance the tension.



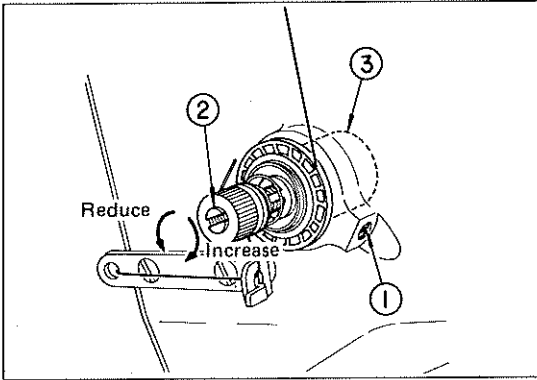

### Thread take-up spring

The tension of the thread take-up spring can be adjusted to change the tension of the thread take-up spring. Firmly tighten screw ① which fastens the tension post socket to the machine arm, insert the blade of a screw driver into the slot in tension post ② and turn it clockwise to increase or counterclockwise to reduce the tension. To change the stroke of the thread take-up spring, loosen screw ① and turn tension post socket ③.

Standard stroke: 8 ~ 12 mm (5/16" ~ 15/32")

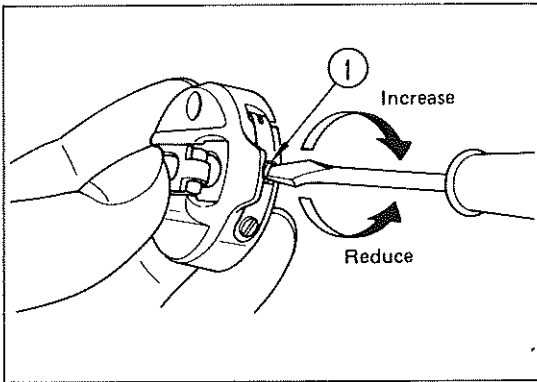

### Bobbin thread tension

The tension of the bobbin thread is adjusted by turning tension adjusting screw ①; turn it clockwise to increase or counterclockwise to reduce the tension.

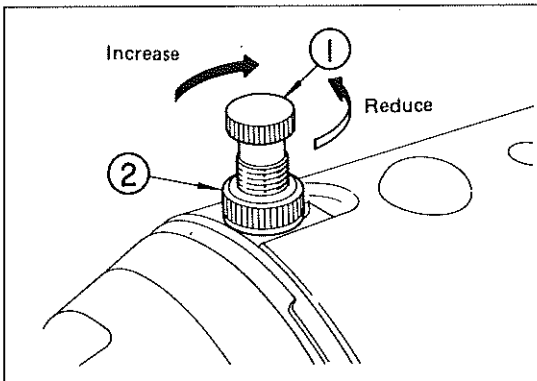

### 8. Adjusting the pressure of the presser foot

The pressure given by the presser foot to the sewing material is adjusted by presser spring regulator ①; turn it clockwise to increase or counterclockwise to reduce the pressure. Tighten locking nut ② after each adjustment.

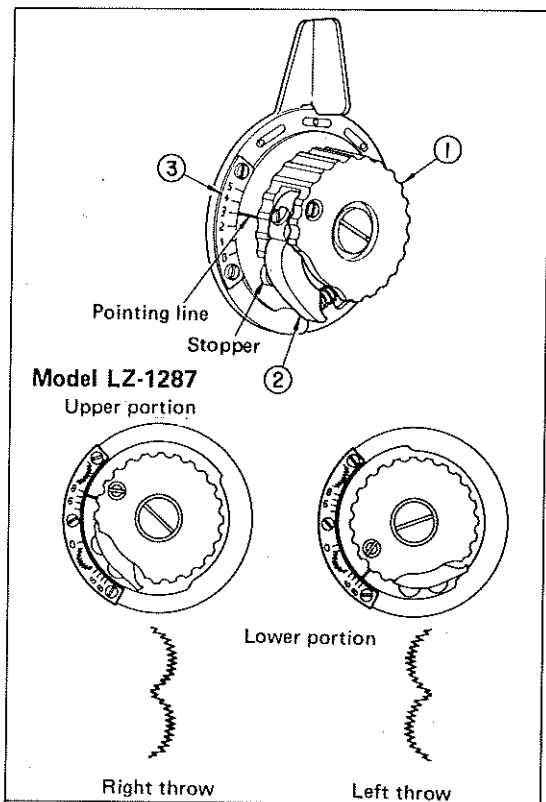

## 9. Adjusting the zigzag width

The zigzag width is adjusted by knob ① .

- (1) Push lever ② with your finger.
- (2) Turn knob ① as you are pushing the lever and set the pointing line to a desired zigzag width which is indicated by zigzag width scale ③ in mm.
- (3) Release the lever, and the knob will be locked up in the given position.

(Note) If your machine is model LZ-1287, set the knob to a desired figure on the upper portion of the zigzag scale when a needle throw to the right is needed or the lower portion of the zigzag scale for the needle throw to the left.

(Caution) Although the zigzag width of model LZ-1286 is set to 8mm (5/16") when delivered, it can be adjusted up to the maximum of 10mm (25/64") by changing the setting position of the stopper.

When the machine is set to the maximum zigzag width, do not operate it at a higher speed than 3,000 s.p.m.

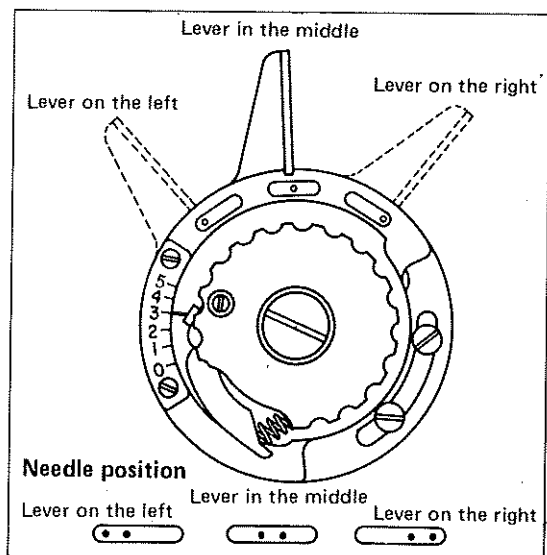

## 10. Needle position adjusting lever

JUKI models LZ-1280 and LZ-1286 have the needle position adjusting lever by which the needle position can be changed as desired.

(Caution) Never change the zigzag width and the needle position while the machine is running.

Do it only after the machine has completely stopped with the needle out of work.

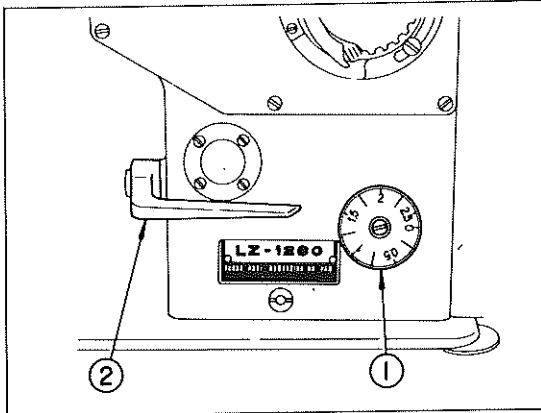

## 11. Adjusting the stitch lengths for the forward and reverse feed

The stitch length is adjusted by stitch length dial ① which is calibrated in mm. Set a figure of the desired stitch length to the pointer pin on the machine arm. To make a reverse stitch, push down reverse feed control lever ②. A reverse stitch is made while the lever is being pushed down. Release the lever to normalize the direction of feed. (Model LZ-1287 does not have the reverse feed control lever)

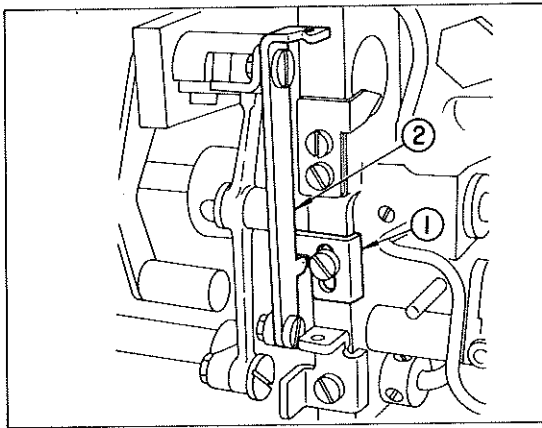

\* If you want to reduce the feed pitch of the reverse stitch, adjust the set position of reverse feed limiter ① which is located on the bottom of the machine.

- (1) Disengage the reverse feed control lever tension spring.
- (2) Set the stitch length dial to a desired reverse stitch length.
- (3) Push down the lever.
- (4) Push the reverse feed limiter against the feed reversal link ② and fasten the limiter.
- (5) Engage the reverse feed control lever tension spring as before.

### III. ADJUSTMENT

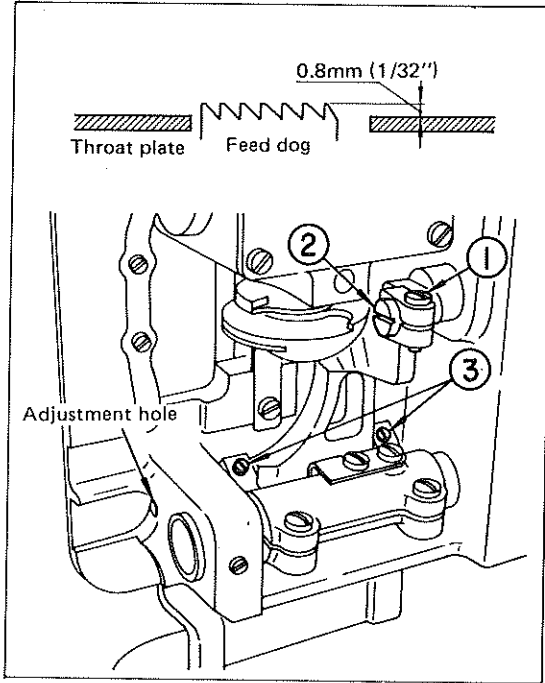

#### 1. Height of the feed dog

To adjust the height of the feed dog, loosen screw ① and turn feed driving link pin ② using a screw driver.

To adjust the inclination of the feed dog, loosen two screws ③ and turn the eccentric shaft inserting a screw driver through the adjustment hole in the machine bed.

The standard height of the feed dog is 0.8 mm (1/32").

It is advisable to change the height to 0.6 mm (1/64") when sewing light-weight material and to 1.0 mm (3/64") for heavy-weight material.

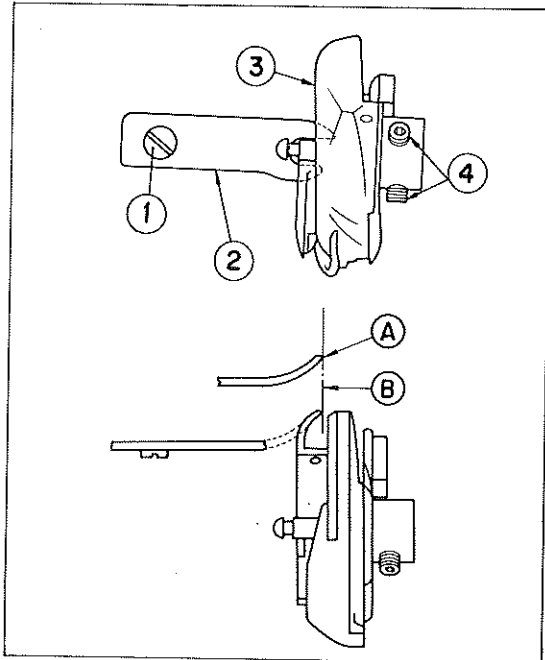

#### 2. Removing and inserting the sewing hook

When you replace the sewing hook, remove it in the following procedures;

- (1) Turn the handwheel to raise the needle.
- (2) Remove the needle, presser foot, feed dog and bobbin case from the machine.
- (3) Remove setscrew ① and take out bobbin case positioning finger ②.
- (4) Loosen two screws ④ and remove sewing hook ③.

(Note) Reverse the above procedures when inserting the sewing hook. Make sure that top end A of the bobbin case positioning finger is aligned with line B. Never let A protrude from line B.

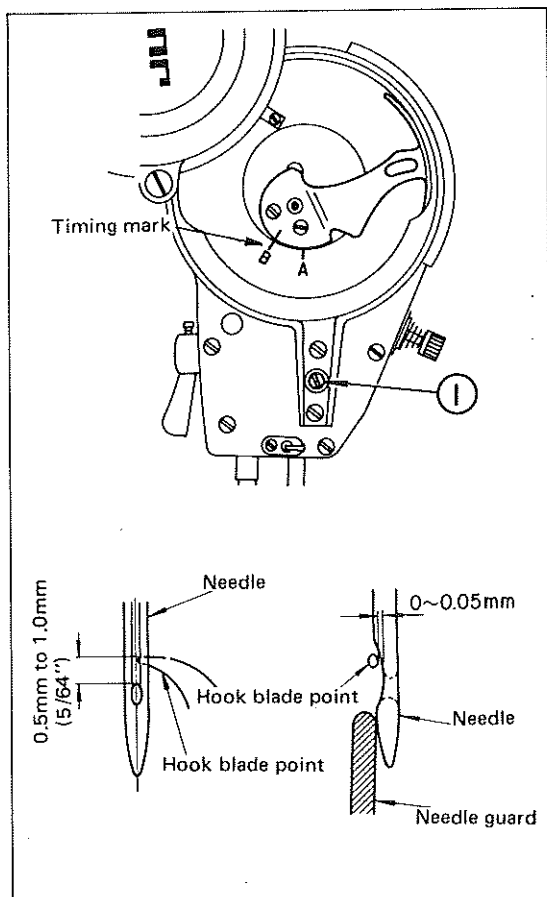

### 3. Relationship between the needle and the sewing hook

Adjust the relationship between the sewing hook and the needle in the following order;

- (1) Set the zigzag width to "0".
- (2) Align the line engraved on the thread take-up lever with timing mark B on the face plate.
- (3) At this point adjust the sewing hook so that its blade point reaches the needle center.
- (4) Provide a clearance of 0.05 mm or less between the needle and the blade point of the sewing hook.
- (5) Set the zigzag width to the maximum and turn the handwheel by hand until the needle reaches its extreme left point allowing the hook blade point to reach the needle center. In this state of the machine, loosen screw ① which clamps the needle bar connection and adjust the height of the needle bar so that the top end of the needle eye is located 0.5 mm to 1.0 mm below the hook blade point as illustrated.

**(Caution)** The needle guard must be installed in such a position that it prevents the needle from hitting the blade of the sewing hook. Adjust the position of the needle guard properly when the sewing hook is replaced.

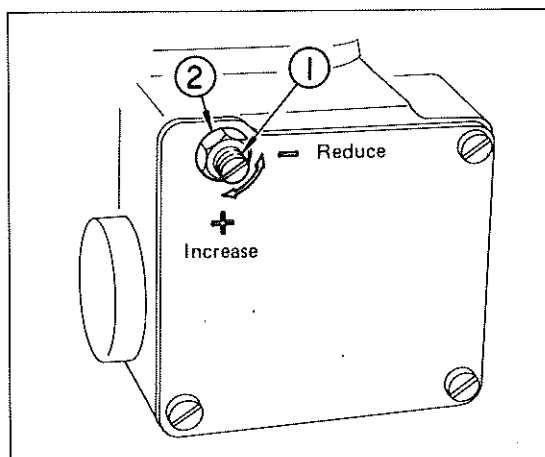

### 4. Adjusting the amount of lubricating oil fed to the sewing hook

Tilt the machine head back and turn adjusting screw ① of the sewing hook gear box after loosening locking nut ② ; turn it clockwise to increase or counterclockwise to reduce the amount of oil.

Firmly tighten the locking nut after the adjustment.

## IV. TROUBLES AND CORRECTIVE MEASURES

Trouble	Cause	Corrective measures	See page
Thread breakage	(1) When the thread gets entangled in the take-up lever.	○ Remove the entanglement.	5
	(2) When the needle thread is threaded in a wrong way.	○ Thread it correctly.	5
	(3) When the thread gets entangled in the sewing hook.	○ Remove the entanglement.	5
	(4) When the needle thread is excessively tight or loose.	○ Adjust the thread tension	5
	(5) When the needle thread slips in the tension controller assembly.	○ Increase the pre-tension.	5
	(6) When the tension of the thread take-up spring is excessively high or low.	○ Adjust the tension of the take-up spring.	6
	(7) When the stroke of the thread take-up spring is excessively large or small.	○ Adjust the stroke of the take-up spring. (Standard stroke: 8 ~ 12 mm)	
	(8) When the timing of the sewing hook and the needle is not matched.	○ Adjust the timing.	10
	(9) When there is a scratch on the thread path of hook, bobbin case, thread take-up lever or any other part.	○ Remove such scratch or replace the component.	
	(10) When the thread is not suitable. (a) The quality of the thread is poor. (b) The thread is too thick for the needle. (c) The thread is broken by heat.	○ Use a thread of good quality. ○ Use a suitable thread or needle.  ○ Use JUKI Silicone Oil Lubricant unit.	
	(11) When the stitch is skipped.	○ Refer to the following paragraphs.	
Stitch skipping	(1) When the needle is inserted in a wrong way. (a) The needle is not entirely inserted into the needle bar. (b) The needle eye is not facing straight to the operator. (c) The needle is facing backwards.	○ Fully insert the needle.  ○ Let the needle eye face straight to the operator. ○ Let the long groove on the needle face to the operator.	3  3 3
	(2) When the needle itself is not suitable. (a) The needle is bent. (b) The quality of the needle is not good. (c) The needle is too thin for the thread.	○ Replace it with a new needle. ○ Use a needle of good quality.  ○ Use a suitable needle or thread. ○ Resharpener the hook or replace it.	
	(3) When the hook blade point is not sharp enough or damaged.		
	(4) When the timing of the sewing hook and the needle is not matched.	○ Adjust the timing properly.	10
	(5) When the height of the needle bar is not correct.	○ Adjust the height of the needle bar.	10
	(6) When the clearance between the needle and the sewing hook is too great.	○ Adjust the clearance.	10
Loose stitch	(1) When the needle thread tension is too low.	○ Increase the needle thread tension.	5
	(2) When the tension of the thread take-up spring is too low.	○ Increase the tension of the spring.	6
	(3) When the tension of the bobbin thread is too high.	○ Decrease the bobbin thread tension.	6
	(4) When the timing of the sewing hook and the needle is not matched.	○ Adjust the timing correctly.	10
	(5) When the thread is too thick for the needle.	○ Use a suitable needle or thread.	
Irregular stitch tightness	(1) When the bobbin thread tension is too low.	○ Increase the bobbin thread tension.	6
	(2) When the bobbin is not wound correctly.	○ Wind up the bobbin evenly.	4
	(3) When there is a scratch on the thread path of the sewing hook, bobbin case, thread take-up lever or any other part.	○ Remove such a scratch or replace the component.	
Needle breakage	(1) When the needle is bent.	○ Use a straight needle.	
	(2) When the quality of the needle is not good.	○ Use a needle of good quality.	
	(3) When the needle is not entirely inserted into the needle bar.	○ Insert the needle into the needle bar as far as it will go.	3
	(4) When the needle hits the sewing hook.	○ Adjust the timing and clearance between the needle and the sewing hook and also the position of the needle guard.	10
	(5) The needle is too thin for the sewing material and thread.	○ Use a suitable needle.	

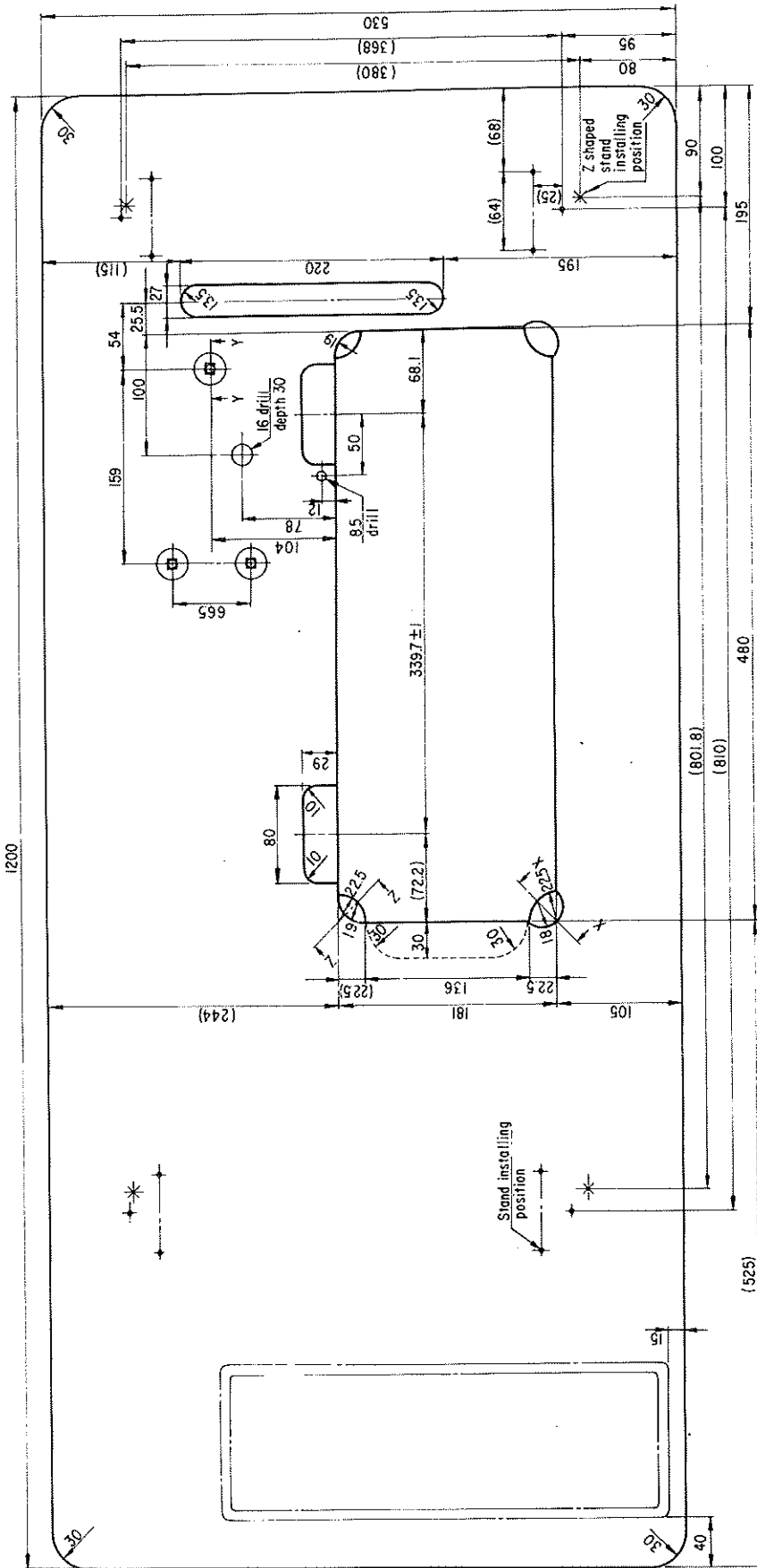

LZ-1280 SERIES  
 DIMENSIONAL DIAGRAM OF THE TABLE

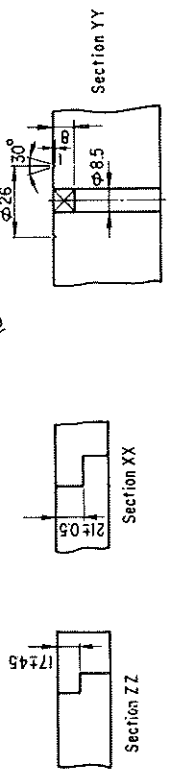

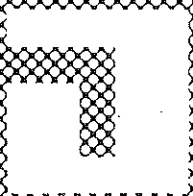

GA Printed in Japan(TE)



**TOKYO JUKI INDUSTRIAL CO.,LTD.**

Head Office & Plant: 2-1, 8-chome, Kokuryo-cho, Chofu-shi, Tokyo, Japan

Business Office: 1-23-3, Kabuki-cho, Shinjuku-ku, Tokyo, Japan

Cable Address: JUKI TOKYO Telex: 22967 JUKITK